



**2010**

**RULE BOOK**

**OPEN-WHEEL MODIFIED**

**[www.delawarespeedway.com](http://www.delawarespeedway.com)**

# **OPEN WHEEL MODIFIED RULES**

**Note:** All modified races will be considered invitational's, to help promote inter-track activity. Weight and handicaps may apply. Contact race director (519) 652-5068 Ext 203 for further information.

Any driver, car owner, chief mechanic who refuses a claim will surrender all prize money and points for that race and may subject themselves to an immediate and indefinite suspension and or fine.

## **AIR CLEANER**

Only round air cleaner element. Minimum 12 inches, Maximum 14 inches diameter by a maximum 4.5 inches high will be permitted. All air shall be filtered through element. Top of air cleaner must be solid, no holes. No forward air ducting allowed. Air cleaner base must be mounted directly to carburetor. No high performance air flow enhancing air cleaners allowed. Must protrude through hood.

## **APPEARANCE**

Race cars must be presentable in appearance at all times. Cars that are considered improperly prepared may be rejected by tech committee at any event. All cars must be painted and professionally lettered (NO BATTERED CARS).

## **BATTERY**

To be anchored securely and separated from driver by a firewall. Location of battery to be mounted no lower than bottom of frame rail and must be in between frame rails, ahead of rear axles. Must be mounted with minimum of two 5/16" bolts.

## **BELLHOUSING**

Original bellhousing or a Delaware Speedway approved all steel clutch housing permitted. Starter mounting position must remain same as on standard production bellhousing. Inspection hole must be in the bellhousing and be large enough to permit inspection of flywheel and pressure plate.

## **BODY STYLE**

**Note:** Some slight concessions may be made on the following body diagram for Knott-produced fiberglass body to fit existing cars.

1995 or newer Compact Sport Coupe style from cowl to rear of car. All body parts should resemble production vehicle. Body material may be fiberglass, aluminum or steel.

**(see diagram on next page)**

# DELAWARE SPEEDWAY MODIFIED BODY DIMENSIONS

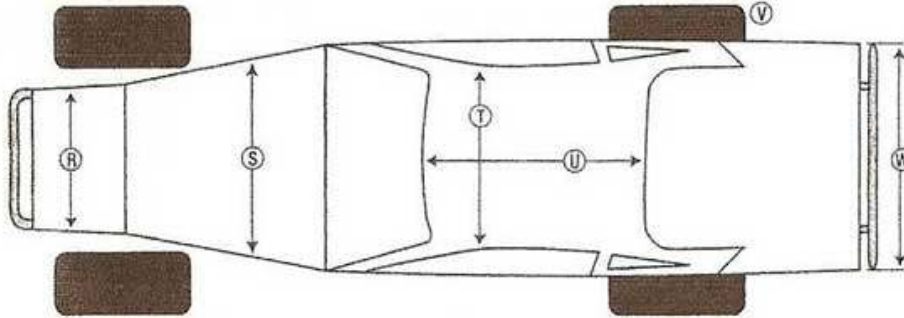
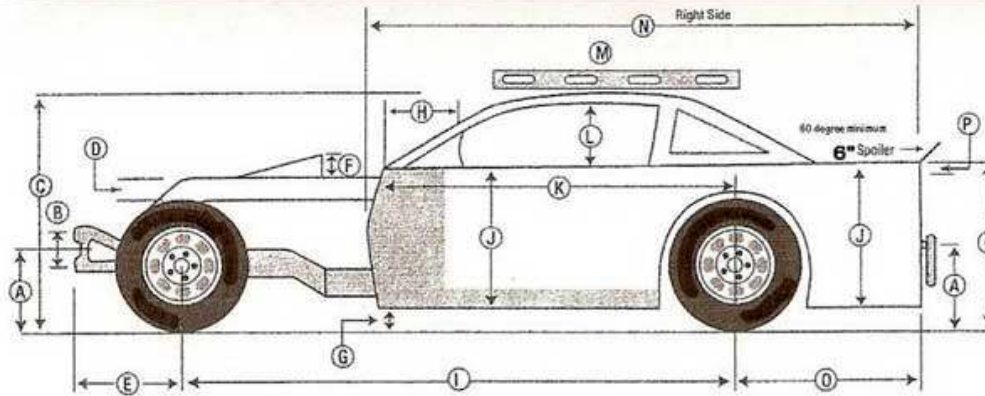

SAIL PANELS: Must meet these dimensions and be the same on both sides.  
(Must resemble manufacturer)

Example:

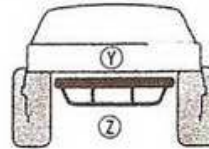
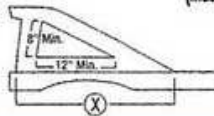

- A 20" max. 16" min. (ground to center of bumpers, front and rear)
- B — 6.5" min. (center to center)
- C 52" max. 44" min.
- D Hood 4" max. drop (sides), sealed off from driver's compartment and max. 3" rake.
- E 42" max.
- F 6" max.
- G — 3.5" min.
- H 19" max., must be same on both sides.
- I 112" max. 108" min.
- J 27" max. 22" min.
- K 72" max. or not past back of block, right side. Left side may extend forward to cover foot box.
- L 18" max. 12" min. opening, both sides.
- M With level, must have between 1/2" and 2" clearance at rear of roof, 1/2" to 5" at front.
- N 120" max. 112" min.
- O 45" max. 40" min.
- P Interior slope is 4" max. front to rear and flat across. If flat at front half of interior you have used up 50% of your 4" so from behind driver to rear you may only have 2". Top of interior must be flush with top of door and quarter panels. An optional escape hatch from driver to passenger door to provide 12" opening allowed.
- Q 38" max. 32" min.
- R Max. no wider than front frame horns, min. 24"
- S 86" max. 24" min. no narrower than radiator.
- T U 10 square feet (applies to both T and U)
- V All tires must be partially outside body and nerfbar and visible from front, rear & top. Minimum combined 6" tire outside of body.
- W 66" max. 53" min. same front to back
- X 24" min.
- Y Min 8" down from top of deck lid following contour of rear quarter, non louvered solid filler panel.
- Z All rear bumpers must be constructed of solid square or round tubing, no wider than five inches outside of rear frame rails and similar to drawing. If rear bumper is wider than five inches outside rear frame rails, it must be capped and bent forward 90 degrees, or constructed in a loop design.

## BUMPERS

May be fabricated. Tubing size 1 1/4" minimum. Bumper must be able to support car when lifted with a wrecker. Bumpers must not be higher than 20 inches to top and not lower than 8 inches. Rear bumpers must be within 2 inches of body and not exceed wheel track width. Front bumper may measure a maximum of 48 inches across the front and must be on center line. Steel flat stock or molded bumpers allowed, maximum 6 inches in height.

## SIDE NERF BARS

May be fabricated from maximum 1 3/4" O.D. round or square tubing. Must not extend past width of tires. Maximum of 2 bars allowed. No plate or channel material allowed. No aluminum allowed.

## WINDSHIELD

Required minimum 1/8 inch thickness of lexan. Minimum of two interior support beams (No Plastic) no more than 1 inch wide and 1 inch deep to follow contour of inside windshield are mandatory. No unapproved markings allowed on windshield. No tinting of front, sides and rear glass.

If bullet-style windshield is used, center window bar is required with maximum 2" x 2" steel mesh on right-hand side and hood must be sealed to firewall.

## **BRAKES**

Calipers: must use magnetic steel single-piston caliper. Piston must be magnetic steel.

Rotors (Magnetic steel only. No drilling. No grooves): original North American factory parts or approved two-piece steel hub and rotor (no aluminum). Front: Minimum 1 inch. Rear: .750 minimum thickness. Aftermarket approved dual master cylinders or one master cylinder with single push rod is allowed. Adjustable balance bar that is adjustable from driver's seat is permitted. Caliper brackets must be mounted in a welded position. Aftermarket rear disc brake hats and rotors allowed. Rear brake proportioning valve permitted.

## **CHASSIS AND SUSPENSION**

Chassis must be fabricated from no less than 3 X 2 by 0.095 box tubing. Chassis built with factory production frames that are at a point no further than 36 " ( thirty six inches) from the rear end housing may use 2 X 2 box tubing. Minimum chassis width is 46 " ( forty six inches) . Spring adjuster ( oad bolts) may be incorporated in the chassis. Minimum ground clearance is 3-1/2" at the lowest point in the frame. Clearance at cross member must be 3-1/2 minimum. Fuel cell container or rear cell guard must maintain a minimum ground clearance of 7 1/2" ( seven one half inches) with the driver at the minimum frame height. An approved tubular front clip is acceptable with 1970-1981 camaro lower a arm pick up points. Upper halo must be a minimum of 30" ( thirty inches) to a maximum of 40" ( forty inches) Halo height is 36" ( thirty six inches) plus/minus 1 " ( one inch)

**Control Arms:** Upper control arms may be stock O.E.M. or tubular and can be moved to desired location (no aluminum). Lower control arms must remain stock O.E.M. or approved tubular lower arm of same length and dimensions and must remain in stock location. Rear suspension control arms may be fabricated from magnetic steel or aluminum material. All mounting hardware must be steel. Steel rod ends only. Maximum length of control arms are 30 inches from mounting hole to mounting hole. Upper A-arms of heim type may use aluminum tubes.

**Springs:** Coil spring suspension permitted on front with coil springs measuring no less than 5 inches (front), 4 1/2inch (rear) in diameter. Aftermarket coils permitted on front and rear. Coil springs must be magnetic steel. Rear suspension may be leaf or coil. Plastic or fiber leaf not permitted.

**Sway Bars:** Sway bars front and rear are optional and may be equipped with heim-ends at the connecting points.

**Shocks:** Shocks may be relocated in chassis. Only one shock per corner permitted. No external adjustments, air assist, remote or aluminum shocks allowed. Approved Monroe or AFCO shock or smooth-bodied steel shock (retail value \$150 CDN maximum per shock). Delaware Speedway reserves the right to implement a \$200 CDN per shock claim rule if necessary. Shock cannot be mounted inside of spring. A SPEC SHOCK MAY BE INTRODUCED IN THE FUTURE.

**Steering and Hubs (two-piece steel optional):** Steering components, steering box and spindles must be O.E.M.-type and in stock locations for frame being used. Aftermarket magnetic steel front spindles of equal kingpin inclination and steering arm lengths optional. Front hubs may be drilled for larger studs or relocated or an approved aftermarket steel hub can be used. Maximum bolt circle 5" by 5". Rack and pinion steering optional. Wheel stud must protrude through

wheel nut. Centre link to be O.E.M. or approved HOWE Racing Enterprises Part # 23396 or Linken Manufacturing Part # LM105. Steel heim ends can be used for tie rods.

**Upper rear end link:** NO coil, spring, or hydraulic device allowed. Damper device & mounting of damper will be allowed. May run a separate 9010 rated shock.

**Ball Joints:** Adjustable ball joints allowed.

### **CLUTCH AND FLYWHEEL**

Stock O.E.M.-type friction disc minimum diameter 9 inches. NO triple disc, NO double disc, NO extensively modified stock units allowed. NO turned, NO drilled, aluminum pressure plates allowed but must have steel face. Total clutch weight to be determined. Flywheel must not weigh less than 13 pounds. The 602 crate option may use the 5 ½" ( five and one half inch) clutch.

### **COOLING SYSTEM**

Radiator must remain stock appearing. Radiator dust screens permitted. Radiator must include liquid overflow container of 1 liter minimum in size and mounted ahead of engine firewall. No anti freeze allowed in the cooling system.

### **DRIVE LINE**

Drive shaft and universals must be stock steel standard production type. Steel, 360-degree retainer loops, 1/4 thick X 2 inches wide, must be positioned at the front and rear of shaft and within 12 inches of U-joint. Drive shaft must be painted white.

### **ENGINE LOCATION**

Engine location will be measured from the centre line of the rear axle assembly to the back of the engine block.

|            |                 |
|------------|-----------------|
| WHEEL BASE | ENGINE LOCATION |
| 108"       | 72" minimum     |

Engine height minimum 10-1/2" measured from the ground to the centerline of crankshaft with frame set of 3-1/2". Engine offset must be within 2 inches of centre line of front cross member. Engine mounts or motor plate types are optional.

### **EXHAUST SYSTEM**

a) Headers optional (no stainless steel). Under chassis or cross over headers allowed 180 degree type headers are disallowed. (Primary tubes crossing over to opposite collector.) Maximum primary tube size of 1 ¾ inches and maximum 3 inch collector allowed. (4 tubes into one collector tube)

OPTION A: Exhaust system must exit outside of car in front of rear wheels but behind the driver.

OPTION B: Exhaust can exit both sides outside of body in front of the rear wheels but behind the driver.

b) MUFFLERS - Existing approved mufflers. Mufflers must be removable for inspection. Mufflers must remain unaltered. A decibel reading of 92 or less at a 100 foot distance will be strictly enforced. Approved mufflers: existing CASCAR muffler, Magnaflow part #11219, IMCO part #7403.

## **FUEL**

Delaware Speedway approved pump gas only. No additives. Fuel will be subject to testing.

## **FUEL CELL**

Mandatory 22 U.S. gallons maximum size allowed. Fuel cell is to be mounted in the trunk area between the frame rails. The minimum ground clearance between the fuel cell and or cell guard is 7 ½" ( seven and one half inch) with the frame height set at 3 ½ " ( three and one half inches) A minimum of 20 gauge steel is to be used for fuel cell case. Bladder-type fuel cell will is mandatory.

## **FUEL LINE**

A single AN-8 (1/2 inch) steel, armored or Kevlar braided fuel line must be used and must be securely fastened under floor. No copper lines. No neoprene. No rubber hose. No plastic or glass filters. If line runs through cab it must run through a steel tube. Tube must be painted red or yellow in contrast to your car.

## **IGNITION**

Race car must be self-starting. Ignition on/off switch must be mounted in the centerline of the vehicle and clearly labeled in such a manner that the engine can be turned off from outside of car in the event of an emergency. See distributor rule for further information.

## **INTERIOR**

Interior of car can be only constructed of minimum 22 gauge steel or aluminum.

a) CLUTCH AND BRAKE PEDALS - Must be located in standard position on left side of transmission and Drive shaft tunnel.

B) DASH - Car must have a fabricated dash in driver's compartment.

c) FIREWALL - Firewall must be constructed of no less than 22 gauge steel. A foot box may be fabricated on left side. Driver's compartment must be totally sealed from engine & race track.

d) FLOOR - Drivers area floor which extends from drive shaft tunnel to left side roll cage and from behind drivers seat, in line with rear roll cage main hoop continuing into drivers foot box may not be Positioned below frame rail and must be constructed of no less than 3/16" magnetic steel intrusion plate.

e) HEAD REST - Approved padded headrest is mandatory and must be securely mounted.

f) INSTRUMENTS - Oil pressure and heat gauge mandatory.

g) MIRROR –

1. Mirror is optional, however if used it must be in the stock location and a maximum size is 3' X 10".

2. If either a full containment seat and or a head/neck support restraint system is used a 3" X 14" mirror mounted in the stock location is permitted. In addition to the larger mirror, an optional left side mirror that is no larger than 2 1/2" maybe installed. The left side mirror may not extend or protrude outside the vehicle.

h) SEAT - Approved bucket seat mandatory. Aluminum seats must be bolted or secured solid, so that seat will not shift or loosen on impact. All seat bolts min. 3/8 inch or larger. Seat must be completely to the left of the centerline of the car and inside frame rail. Aluminum seats are mandatory. Full upper body head and shoulder containment seat is highly recommended however is mandatory on all new cars..

I) SHIFTER - Conventional type shifter. Double rods permissible. Shifter must have boot or cover at all times.

j) STEERING WHEEL - Removable racing steering wheel with quick release metal hub are mandatory. Steering wheel pad is mandatory.

## **PAINT AND LETTERING**

a) A detailed professional quality job is mandatory on all cars. Car base colour and number should be of high contrast for maximum number visibility. All body components must be painted with no "patch" panel or unpainted plastic/fiberglass material visible.

b) A minimum 18" high and 3" stroke number is required on quarter panels behind rear wheel opening. A 28" high (minimum) 3" stroke (minimum) number must be facing outward on roof, readable from right side. All cars are required to have a management assigned number; however, management reserves the right to specify number changes to prevent duplication. Management reserves the right to approve or disapprove commercial or editorial messages appearing on competing cars.

NOTE: Both door panels of car may be used for your sponsor message. Hood, rear deck and rear bumper areas are also areas available for sponsor decals. Management retains the right to use the top 5" of the windshield and the leading edge (first 12") of the door for contingency sponsors.

## **RADIOS**

Approved 1-way radio receiver mandatory. Must receive frequency UHF 451.7125

## **REAR AXLE**

Rear axle ring and pinion may be any gear ratio. Differential O.E.M. carriers or spools permitted only. Maximum bolt circle is 5 x 5". Only all-steel full floating rear end assemblies permitted (including hub ). Steel aftermarket spools are permitted. NO cambered rear axle assemblies allowed. No limited slip devices allowed.

## **ROLL CAGE**

Steel roll cage must be constructed of no less than 1-3/4" O.D. 0.095. Must have 4 door bars on drivers side with top bar not exceeding 19" +/- 1" from top of rail. Roof hoops must measure no less than 30 inches, maximum 40 inches O.D. across (left to right). Halo height 36" +/- 1" from the top of the rail to the top of the halo. Rear hoops must extend over drivers head and attach to main frame rails. Right side door bars must at least form an X with top bar running from

front to back 19" +/- 1" from top of roof. Roll bars in driver's immediate area must be padded. All bars running rearward and forward of roll cage assemble may be constructed of tubing of no less than 1-1/4" O.D.

## **SAFETY**

APPAREL - Drivers are required to wear full coverage, one or two piece Nomex 111 or Nomex, P.B.I, Kevlar Blend Material. Fire retardant gloves and socks are mandatory. Fire-retardant under garments strongly recommended. Driver's helmet must conform to SA 2005 standards; SA 2010 highly recommended and have a certification sticker visible inside the helmet. It is highly recommended that drivers wear eye protection designed for auto racing. Driver's apparel must be clean at all times. No nylon shoes are allowed. 2010 is the last year for the SA 2000 helmet to be eligible.

b) BELTS AND HARNESS - A quick release SFI approved 5-point harness of no less than 3" in width good condition are mandatory. Belts must be securely fastened to the frame, cross member or roll cage by means of a suitable reinforced mounting, in such a manner that all fittings are in a direct line with the direction of pull, as per manufacturer's instructions. No inertia reels allowed and under no circumstances are bolts inserted through belt webbing accepted for mounting. Anti-submarine V-belt highly recommended. Belts may not be any older than 3 years (manufacturers date). All belts and mounting will be subject to technical inspection.

c) FIRE CONTROL - Race cars must have an approved fire extinguisher, with a recharge slip dated back no later than 9 months, mounted on the right side and within reach of driver when seat belts are fastened. This extinguisher must be mounted to an approved mounting bracket. On board fire systems highly are recommended.

D) WINDOW NET - An approved nylon mesh net must be installed in driver's side window opening. Net size must be at least 16" X 18". Net must be installed so it is tight. Window net anchors must be attached to roll bars, not body. Window nets must be quick release type. Net must be permanently anchored at the bottom and release at the top. Management highly recommends wide mesh nets.

## **TIRES**

Only approved tires permitted. Altering tires by treatment (softeners, etc.) is illegal. Durometer and/or other devices will be used to check tires. A tire inventory rule will apply in 2010.

## **TRANSMISSION (MANUAL)**

Transmission must be 3 or 4 speed. Must have reverse gear. Transmission must be stock with no internal lightening of parts, not altering of shift patterns and or ratios, and original brass syncro's must be installed. Rod-type shifter optional.

## **TRANSMISSION (AUTO)**

Automatic transmissions may be strengthened. Modifications to shifting patterns are permitted, provided full shift pattern is retained. Scatter shield is highly recommended with automatic transmission. Stock-type working torque with a minimum weight of 25 lbs wet. Stall test will be conducted in both forward and reverse gears. Transmission oil coolers are mandatory but must not be mounted inside driver's compartment however must be contained inside the body of the car. Transmission must be 2 or 3 speed automatic only. Must have approved shifter.

For visiting competitors. If your vehicle has either a lock up convertor and or direct drive coupler they will be allowed to run however a weight handicap will be applied by the technical committee. It is the responsibility of the driver to notify the technical team of this prior to any on track activity.



## **WEIGHT**

|                                       | <b>Min. Weight</b> | <b>Frame Height</b> | <b>Max. RPM</b> |
|---------------------------------------|--------------------|---------------------|-----------------|
| With Crate Engine #88958602 (350 hp)  | 2525 lbs.          | 3.5"                | 6400            |
| With Crate Engine (approved 400 hp)   | 2700 lbs.          | 3.5"                | 6400            |
| With Built Engine (Option B 2 barrel) | 2675 lbs.          | 3.5"                | 7000            |
| With Built Engine (Option C 4 barrel) | 2700 lbs.          | 3.5"                | 6400            |

58% left-side weight. Car weight and height to be measured with driver.

Cars with stock clip chassis will have a 50lb ( fifty pound) weight reduction based on specific engine package.

Allowance of 1% of total weight will be allowed on events of 50 laps or more. Management reserves the right to increase or decrease the weight of the race car to equal competition if necessary.

## **WEIGHT LOCATION**

Weight must be bolted on no lower than frame rails in block form, no less than 10 lb pieces. No weight to be added rearward of fuel cell. All ballast weight must be either fastened to or encased within the frame rail. All added weight must be double bolted and painted white, with car number clearly marked on each piece. Loss of add-on weight will result in a severe penalty.

## **WHEELS**

15" diameter steel racing wheels with a maximum width of 8" measured from bead seat to bead seat will be allowed. Max. bolt cir. 5 x 5". NO LIGHT WEIGHT WHEELS. A minimum of 2 ( two) threads must protrude the wheel nut with the tire and wheel assembly properly torqued.

## **WHEEL BASE**

All cars will maintain a minimum wheelbase of 108" plus or minus 1/2". Wheel track width will be a maximum of 80" measured from outside of tire budge measured at spindle height.

# **ENGINE OPTIONS**

## **OPTION A: CRATE ENGINE**

Only approved, sealed, unaltered engines. No changes, substitutions or modifications to engine.

Any tampering, alterations, or violations with respect to the crate engine program will result in the immediate suspension of the driver, car owner, and chief mechanic for a minimum of 1 year (365 days) from the date of the infraction. Further monetary fines and reduction of points will be assessed by the technical committee. The tampered engine which must be removed at the team's expense will be impounded at both the team's expense and risk until the ruling is finalized. The speedway reserves the right to destroy all tampered with parts.

Approved engines are:

350hp Chevrolet 350/350 Circle Track Crate Engine Part # 88958602

400hp Chevrolet 350/400 Limited Late Model Crate Engine Part # 88958604

400hp Ford McGonigle Crate Engine Part # ASA425LM  
400hp Ford Part 347 Sealed Crate Engine # M-6007-D347SR  
400hp Dodge 360 Crate Engine Part # P5007958

All three makes to use Holley carburetor part # 80541-1 (650 CFM) unaltered as per two-barrel rule. Must bolt to intake with no spacer.

### **DISTRIBUTOR**

- Stock type distributor and stock coil allowed. Refer to stock definition in the general rules section for further clarification. MSD distributor and or MSD 6A or 6AL box optional. The box must be mounted on the right side of the dash, out of the drivers reach, and the rev chip must be accessible through the right hand side of the vehicle. Soft touch rev control part 8728 must be mounted on the right hand side of the dash ( same as ignition box) if a stock distributor and stock module are used.
- A claim rule of \$200.00 will be mandated on all MSD modules ( 6A or 6AL).

### **OPTION B: BUILT ENGINE 2 bbl.**

Definition: Parts available from your local dealer through ordinary parts catalogue may be accepted as stock. Parts ordered through dealer performance catalogues will not necessarily be considered legal.

| <b>ENGINE</b>          | <b>MAXIMUM<br/>OVERBORE</b> | <b>MAXIMUM<br/>DISPLACEMENT</b> |
|------------------------|-----------------------------|---------------------------------|
| CHEVROLET 305-350      | .060                        | 360 cu.in                       |
| DODGE 318-360          | .060                        | 371 cu.in                       |
| FORD 351(Windsor only) | .060                        | 362 cu.in                       |

A) BLOCK ASSEMBLY: Must be production with standard external measurements in all respects with the exception of the permissible overbore. No aluminum blocks permitted. Stock production lifter bore must be maintained. Sleeving of lifter bores permitted to a maximum of 4. Deburring of block and parts permitted. Balancing optional. Pistons must be O.E.M. or cross reference to O.E.M. (ex. T.R.W part# cross reference to GM part#). O.E.M. rods allowed or the following Eagle part #'s will be optional: Chevrolet 327 and 350 – Eagle part #CRS5700B3D 5.70 length, Dodge – Eagle part #CRS6123C3D, Ford – Eagle part #CRS5956F3D. No GM 6" rod allowed. Deburring of stock rods permissible. Stock identification marks must be retained. Crankshaft and harmonic balancer must be stock O.E.M production. Top of block to piston clearance may be .00 deck. No roller or roller tip rockers allowed.

B) CAMSHAFT: Optional solid or hydraulic cam allowed. Camshaft must be driven the same as approved production engine. Gear drive not allowed. Solid or hydraulic valve lifters optional. Roller tappets, mushroom valve lifters and any type of mechanical assistance exerting a force to assist in closing the lifter and/or push rod, commonly known as "Rev Kits" will not be permitted. Only flat tappet straight barrel lifters permitted. Rocker arms and push rods must be stock O.E.M production or stud mount trunion—type roller-tip rockers are optional. Chevrolet and Dodge must use a 1.5 to 1 ratio. Ford must use a 1.6 to 1 ratio. No exotic materials or titanium.

C) CARBURATION: One two barrel Holley 500CFM part #0-4412 or HP Equivalent. No modifications. Jets and power valve may be changed. Accelerator pump discharge nozzles may be changed utilizing straight type only. Spacer/adaptor thickness to be no thicker than 1 1/4" and to include gaskets. (i.e. Distance from bottom of carburetor to top of intake manifold where carb sits no taller than 1 1/4" including gaskets.)

D) CYLINDER HEADS: Only stock O.E.M cast iron heads allowed. Absolutely no deburring, grinding, or polishing of intake or exhaust ports allowed. Chevrolet engines are restricted to 1 15/16" intake valve diameter and 1 1/2" exhaust valve diameter. (All other engines must be stock for year and engine model used). Chevrolet engines are restricted to 64 c.c. minimum chamber volume. Guide plates allowed. Maximum valve spring diameter 1.225 (Chevrolet).

Composition gaskets of no less than .039 compressed thickness must be used on all cylinder heads. Ford and Chrysler cylinder heads are restricted to 64 CC. Note: No camelback heads.

E) DISTRIBUTOR: Stock type distributor and stock coil allowed. Refer to stock definition in the general rules section for further clarification. MSD distributor and or MSD 6A or 6AL box optional. The box must be mounted on the right side of the dash, out of the drivers reach, and the rev chip must be accessible through the right hand side of the vehicle. Soft touch rev control part 8728 must be mounted on the right hand side of the dash ( same as ignition box) if a stock distributor and stock module are used.

- A claim rule of \$200.00 will be mandated on all MSD modules ( 6A or 6AL).

F) FUEL PUMP: Stock type mechanical pump only. Absolutely no electric fuel pumps. No plastic or glass fuel filters allowed.

G) INTAKE MANIFOLD: Approved aluminum intakes allowed. No grinding or coating of any type permitted internally or externally. An Edelbrock aluminum intake manifold is optional. Chevrolet engines – Edelbrock part #7101 or #7116. Dodge engines – Edelbrock part #1776 or Mopar part #P4876335. Ford engines – Edelbrock part #7181. No modifications. As produced by manufacturer only.

NOTE: The carburetor adapter to be used with Edelbrock intakes is Canton Racing Products part #85-060, unaltered as produced or equivalent (i.e., Bicknell # BRP 376 / Wilson # 044111).

H) OIL PAN AND LUBRICATION: Any oil is permissible. Oil pressure may be regulated at discretion of owner or driver. Wet sump systems only. No external oil pump(s)(aftermarket) allowed. No external reservoir tanks permitted. Modifying of oil pan for greater volume of oil permitted. Steel oil pans only. Oil pan must not be lower than cross member or frame rails of race car. Any approved oil filters and breather caps may be used.

1-1/4"-inch NPT inspection hole mandatory or oil pan may be subject to removal for inspection. Inspection hole must be located so crank shaft numbers can be inspected.

### **OPTION C: NEW BUILT ENGINE 4BBL OPTION FOR 2007 AND BEYOND**

| <b>MAKE OF CAR</b> | <b>ENGINE</b> | <b>MAXIMUM OVERBORE</b> | <b>MAXIMUM DISPLACEMENT</b> |
|--------------------|---------------|-------------------------|-----------------------------|
| Chevrolet          | 350           | .045                    | 358 inches                  |
| Dodge              | 360           | .045                    | 368 inches                  |
| Small block Ford   | 351           | .045                    | 360 inches                  |

A) CYLINDER BLOCK ASSEMBLY (Short Block)

- All engine blocks must be product of the manufacturer of the make for the engine being used in competition. Aftermarket engine blocks will not be permitted.
- The engine block must retain all engine dimensions with the exception of the maximum allowable overbore and the surfacing of the engine block deck.
- Angle cutting of the engine block will not be permitted.
- Aluminum blocks will not be permitted.
- Only iron cylinder sleeves may be used to repair.
- Must maintain stock lifter bore: Dodge .904 inch, Ford .875 inch, Chevrolet .842 inch.
- Repair sleeving of lifter bores permitted to a maximum of 4.
- Deburring of block permitted. Excessive grinding, lightening, polishing, painting or coating internally, screening or vent stacking is not allowed.

- Crankshaft must be stock OEM-type. Must have factory I.D. numbers that are legible through inspection hole in oil pan (except Chrysler). Only standard magnetic steel or cast-iron production design crankshafts will be permitted. No lightening, knife edging or polishing allowed. Balancing okay.
- Harmonic balancer stock iron elastamer-type only. No aftermarket or aluminum. Must maintain stock dimensions and weight.
- Connecting rods. Stock-type I-Beam rods only of stock length for manufacturer: General Motors 5.7 inches, Ford 5.956 inches, Chrysler 6.125 inches. Must be magnetic steel, iron or powdered metal. No titanium, aluminum, stainless or exotics.
- Must use OE-type insert bearings. No rollers.
- Piston. Stock-type or flat-top three ring pistons with all rings in place. Must use stock pin and mounting (i.e., pressed fit if equipped). Must not protrude through deck.
- Head Gasket. Any composite gasket allowed. **MUST MAINTAIN 9.5-1 COMPRESSION RATIO MAXIMUM.** To be determined by tech officials.

#### B) CAMSHAFT

- Mandatory flat tappet hydraulic camshafts. Maximum valve lift .500 inch measured at valve with zero lash. No mushroom lifters. No rollers. Must use stock-type timing chain and gears.
- Cams with excessively steep ramping and high overlap will not be allowed.
- Must use manufacturer's firing order.

#### C) CARBURETOR

- All three makes to use Holley carburetor part # 80541-1 (650 CFM) unaltered as per two-barrel rule. Must bolt to intake with no spacer.

#### D) CYLINDER HEADS

- Only stock O.E.M. cast iron heads allowed. Absolutely no deburring, grinding, acid dipping, acid porting or polishing of intake or exhaust ports allowed.
- Must use 11/32" stem. No undercut valves. No hollow valves. No titanium. No sodium.
- Maximum valve size: General Motors 1.94" intake and 1.50" exhaust, Ford and Chrysler 1.94" intake and 1.60" exhaust
- Ford may use Windsor Jr. 180 #053030 or stock iron heads.
- No GM camelback or angle plug heads. No aluminum heads.
- Must use OE-type valve spring and retainers (i.e., maximum diameter 1.255" for standard spring / 1.310 for beehive spring).
- Stock rockers, push rods and valve train to be used. Guide plates on Ford and GM optional. Shafts mandatory on Chrysler. No aluminum, titanium exotic metals allowed.

#### E) DISTRIBUTOR

- Stock type distributor and stock coil allowed. Refer to stock definition in the general rules section for further clarification. MSD distributor and or MSD 6A or 6AL box optional. The box must be mounted on the right side of the dash, out of the drivers reach, and the rev chip must be accessible through the right hand side of the vehicle. Soft touch rev control part 8728 must be mounted on the right hand side of the dash ( same as ignition box) if a stock distributor and stock module are used.
- A claim rule of \$200.00 will be mandated on all MSD modules ( 6A or 6AL).

#### F) INTAKE MANIFOLD

- Chevrolet engines may use Edelbrock part #7101 or #7116. Dodge engines may use Edelbrock part #7176 or Mopar #P4876335 or P5007381. Ford engines may use Edelbrock part #7181. Manifold must remain stock and unaltered. No port matching, grinding, acid dipping or porting.
- Two adjacent intake bolts on each side of manifold must be drilled for sealing.

#### G) OIL PAN

- **Option 1:** Any O.E.M. factory production oil pan permitted. No altering of stock oil pan permitted. Windage tray may be used. Oil filter must be directly attached to block. Minimum ground clearance must be retained.
- **Option 2:** Aftermarket racing-type kickout oil pan permitted. The oil pan must be wet-sump type and must be manufactured using a production-type pan with only a wet sump reservoir added to the bottom. All bolt holes and bolt hole flanges must be visible. Kickouts will not be permitted between the bolt-on flanges and the top of the added sump. Spacers other than sealing gaskets will not be permitted between the oil pan side rails and the engine block surface. Must be made of magnetic steel only.
- 1-1/4"-inch NPT inspection hole mandatory or oil pan may be subject to removal for inspection. Inspection hole must be located so crank shaft numbers can be inspected.

## **PULLEYS**

Aftermarket V-belt pulleys allowed (5/16<sup>th</sup>" minimum thickness).

## **WATER PUMP**

Aluminum water pumps are allowed. Must be V-belt drive.

NOTE: Interpretation of these rules will be solely up to the judgment of the officials in charge of the area in question. DELAWARE SPEEDWAY reserves the right to impound non-complying components with no compensation to the owner(s). Noncompliance with the specifications outlined herein may subject violating teams to disqualification, loss of points and moneys and/or fine.

**ALL DECISIONS BY PIT STEWARDS, CHIEF TECHNICAL INSPECTOR OR DELAWARE SPEEDWAY EXECUTIVE COMMITTEE MEMBERS WILL BE FINAL. ALL RULES SUBJECT TO INTERPRETATION BY DELAWARE SPEEDWAY OFFICIALS. RULE BOOKS WILL BE ISSUED TO MEMBERS. ALL EQUIPMENT NOT GOVERNED BY THE AFOREMENTIONED RULES ARE TO BE SUBMITTED TO DELAWARE SPEEDWAY, NOT LESS THAN 30 DAYS PRIOR TO THE DATE OF INTENDED USAGE. NO EQUIPMENT WILL BE CONSIDERED APPROVED BY REASON OF HAVING PASSED THROUGH INSPECTION UNOBSERVED. RULES APPLY TO ALL RACE EVENTS.**